

**DALLAS**  
SEMICONDUCTOR

**DS1812**  
5V EconoReset with Active  
High Push-Pull Output

**FEATURES**

- Automatically restarts a microprocessor after power failure
- Maintains reset for 150 ms after  $V_{CC}$  returns to an in-tolerance condition
- Reduces need for discrete components
- Precision temperature-compensated voltage reference and voltage sensor
- Low-cost TO-92, or space saving surface mount SOT-23 packages available
- Push-Pull active high output
- Operating temperature  $-40^{\circ}\text{C}$  to  $+85^{\circ}\text{C}$

**PIN ASSIGNMENT**

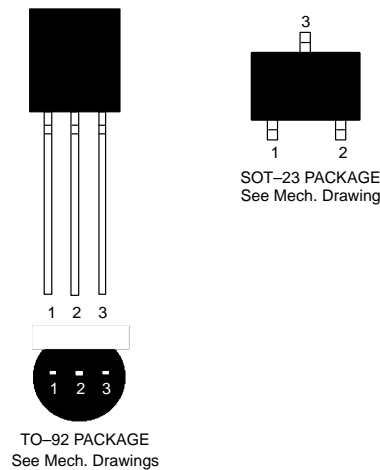

**PIN DESCRIPTIONS**

**TO-92**

1	RST	Active High Reset Output
2	$V_{CC}$	Power Supply
3	GND	Ground

**SOT-23**

1	RST	Active High Reset Output
2	$V_{CC}$	Power Supply
3	GND	Ground

**DESCRIPTION**

The DS1812 EconoReset uses a precision temperature reference and comparator circuit to monitor the status of the power supply ( $V_{CC}$ ). When an out-of-tolerance condition is detected, an internal power-fail signal is

generated which forces reset to the active state. When  $V_{CC}$  returns to an in-tolerance condition, the reset signal is kept in the active state for approximately 150 ms to allow the power supply and processor to stabilize.

**OPERATION – POWER MONITOR**

The DS1812 provides the function of detecting out-of-tolerance power supply conditions and warning a processor based system of impending power failure. When  $V_{CC}$  is detected as out-of-tolerance, the RST signal is

asserted. On power-up, RST is kept active for approximately 150 ms after the power supply has reached the selected tolerance. This allows the power supply and microprocessor to stabilize before RST is released.

**BLOCK DIAGRAM (CMOS OUTPUT) Figure 1**

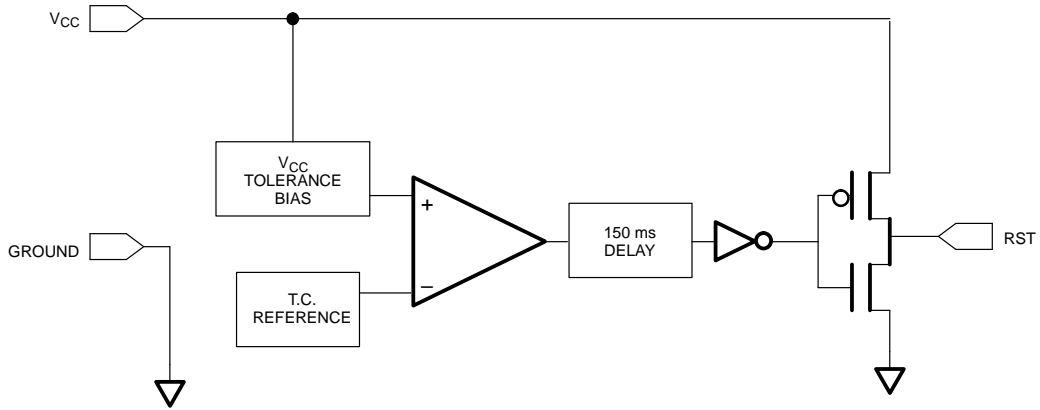

**APPLICATION EXAMPLE Figure 2**

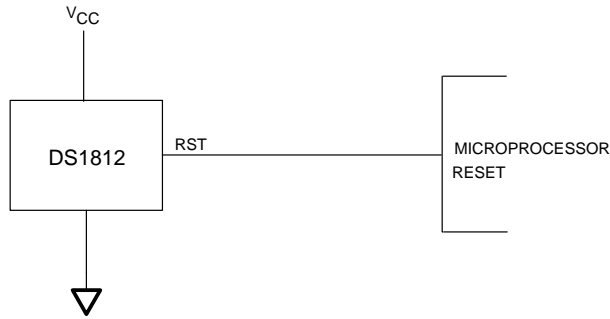

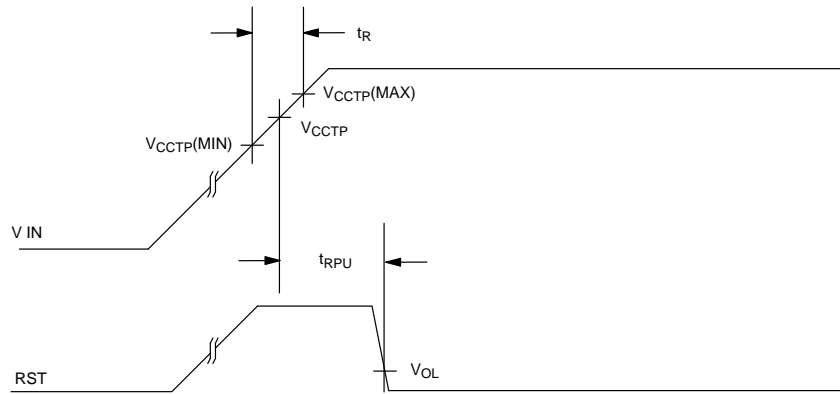
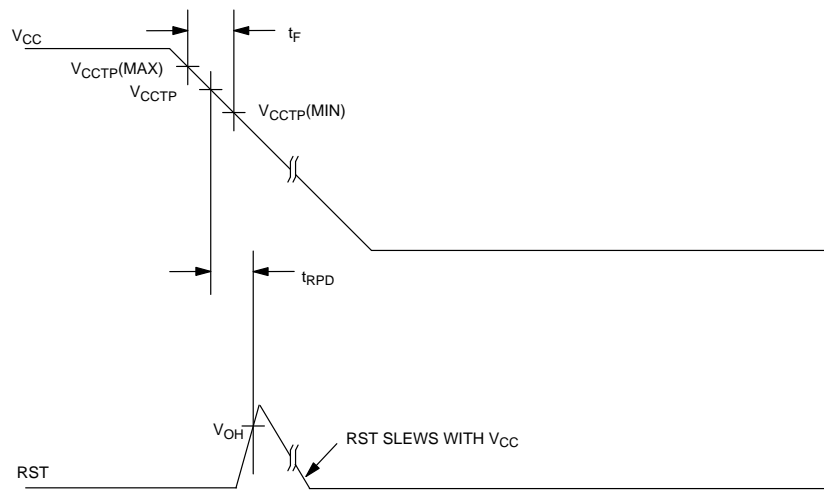
**TIMING DIAGRAM: POWER UP** Figure 3**TIMING DIAGRAM: POWER DOWN** Figure 4

**ABSOLUTE MAXIMUM RATINGS\***

Voltage on V <sub>CC</sub> Pin Relative to Ground	-0.5V to +7.0V
Voltage on RST Relative to Ground	-0.5V to 5V <sub>CC</sub> +0.5V
Operating Temperature	-40°C to +85°C
Storage Temperature	-55°C to +125°C
Soldering Temperature	260°C for 10 seconds

\* This is a stress rating only and functional operation of the device at these or any other conditions above those indicated in the operation sections of this specification is not implied. Exposure to absolute maximum rating conditions for extended periods of time may affect reliability.

**RECOMMENDED DC OPERATING CONDITIONS**

(-40°C to +85°C)

PARAMETER	SYMBOL	MIN	TYP	MAX	UNITS	NOTES
Supply Voltage	V <sub>CC</sub>	0.0		5.5	V	1

**DC ELECTRICAL CHARACTERISTICS**(-40°C to +85°C; V<sub>CC</sub> = 1.2V to 5.5V)

PARAMETER	SYMBOL	MIN	TYP	MAX	UNITS	NOTES
Output Voltage @ 0–500 μA	V <sub>OH</sub>	V <sub>CC</sub> -0.5V	V <sub>CC</sub> -0.1V		V	1
Output Current @ 2.4 volts	I <sub>OH</sub>		350		μA	2
Output Current @ 0.4 volts	I <sub>OL</sub>	+10			mA	2
Operating Current V <sub>CC</sub> < 5.5	I <sub>CC</sub>		30	40	μA	3
V <sub>CC</sub> Trip Point (DS1812–5)	V <sub>CCTP</sub>	4.50	4.62	4.75	V	1
V <sub>CC</sub> Trip Point (DS1812–10)	V <sub>CCTP</sub>	4.25	4.35	4.49	V	1
V <sub>CC</sub> Trip Point (DS1812–15)	V <sub>CCTP</sub>	4.00	4.13	4.24	V	1
Output Capacitance	C <sub>OUT</sub>			10	pF	

**AC ELECTRICAL CHARACTERISTICS**(-40°C to +85°C; V<sub>CC</sub> = 1.2V to 5.5V)

PARAMETER	SYMBOL	MIN	TYP	MAX	UNITS	NOTES
RESET Active Time	t <sub>RST</sub>	100	150	300	ms	
V <sub>CC</sub> Detect to RST	t <sub>RPD</sub>		2	5	μs	
V <sub>CC</sub> Slew Rate (V <sub>CCTP</sub> (MAX) to V <sub>CCTP</sub> (MIN))	t <sub>F</sub>	300			μs	
V <sub>CC</sub> Slew Rate (V <sub>CCTP</sub> (MIN) to V <sub>CCTP</sub> (MAX))	t <sub>R</sub>	0			ns	
V <sub>CC</sub> Detect to RST	t <sub>RPU</sub>	100	150	300	ms	4

**NOTES:**

1. All voltages are referenced to ground.
2. Measured with V<sub>CC</sub> ≥ 2.7 volts.
3. Measured with RST output open.
4. t<sub>R</sub> = 5 μs.

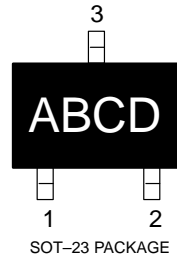
**PART MARKING CODES**

"A", "B", & "C" represents the Device Type.

810	-	DS1810
811	-	DS1811
812	-	DS1812
813	-	DS1813
815	-	DS1815
816	-	DS1816
817	-	DS1817
818	-	DS1818

"D" represents the Device Tolerance.

A	-	5%
B	-	10%
C	-	15%
D	-	20%